

Tachometer Installation and Operation Instructions

For Street Eliminator, Comp Eliminator, Pro Eliminator, and Top Eliminator Tachometers

VDO® Instruments

THE INSTRUCTIONS FOR INSTALLATION AND ELECTRICAL WIRING FOR THESE TACHOMETERS FOLLOW. USE IS RESTRICTED TO 12 VOLT NEGATIVE GROUND ELECTRICAL SYSTEMS.

Parts List

Item	Description	Quantity
1.	Tachometer	1
2.	Decals, 2" x 4" (not contingency decals)	2
3.	18-Gauge Wire, 4'	1
4.	3-Conductor Shielded Wire, 10'	1
5.	Posi-Lock™ Connectors	4
6.	Rubber Mounting Grommet	1
7.	Contoured Mounting Foot	1

Optional Items Which May Be Needed:

Magneto Interface Box #340 030
 Remote Keypad Cable, 6' #240 207
 Flush Dash Mounting Bracket #240 104
 On-Dash Mounting Bracket #240 103

CAUTION: Read these instructions thoroughly before making installation. Do not deviate from assembly or wiring instructions. Always disconnect battery ground before making any electrical connections. If in doubt, please contact your dealer or VDO Instruments at (703) 665-2428.

Tachometer Installation

Installing the tachometer is a three-step process. First, you must program the tachometer to match the number of cylinders your engine has and the type of ignition your are using. Next, you must determine where to mount the tachometer and which optional mounting brackets, if any, you need. Finally, after mounting the tachometer, you must wire it.

I. Programming the Tachometer

1. Start by removing the four (4) cap nuts and washers on the back of the tachometer. (For the **Street Eliminator**, see Diagram A; for the **Comp Eliminator**, Diagram B; for the **Pro Eliminator**, Diagram C; and for the **Top Eliminator**, Diagram D.)

2. Before removing the mounting cup, spray the five wires with any of the following products: WD40, ARMOR-ALL, or any rubber/vinyl protectorant. This will allow the wires to slide through the rubber grommet.

3. Take off the back cap. Set the selector switches to match the cylinder and ignition type you are using. Switches 1 & 2

will input the number of cylinders your engine has. Switch 3 applies only to the Top Eliminator. It allows you to choose either 50 or 200 seconds of recording memory. We recommend that you use the shortest memory practical for your application. Switch 4 is used to input the type of ignition system on which you are installing the tachometer—electronic, CDI, or standard. For the selector switch settings that apply to the model of Eliminator Tachometer you are installing, consult either Diagram A, B, C, or D. Each tachometer is preset to eight cylinder engines and electronic ignitions (and the **Top Eliminator** to 50 seconds). You must change the selector switches to match the number of cylinders and the ignition your are using, or the tachometer will not work properly. Should you ever need to replace the Type 194 light bulb, remove the back cap as you would to set the Selector Switches.

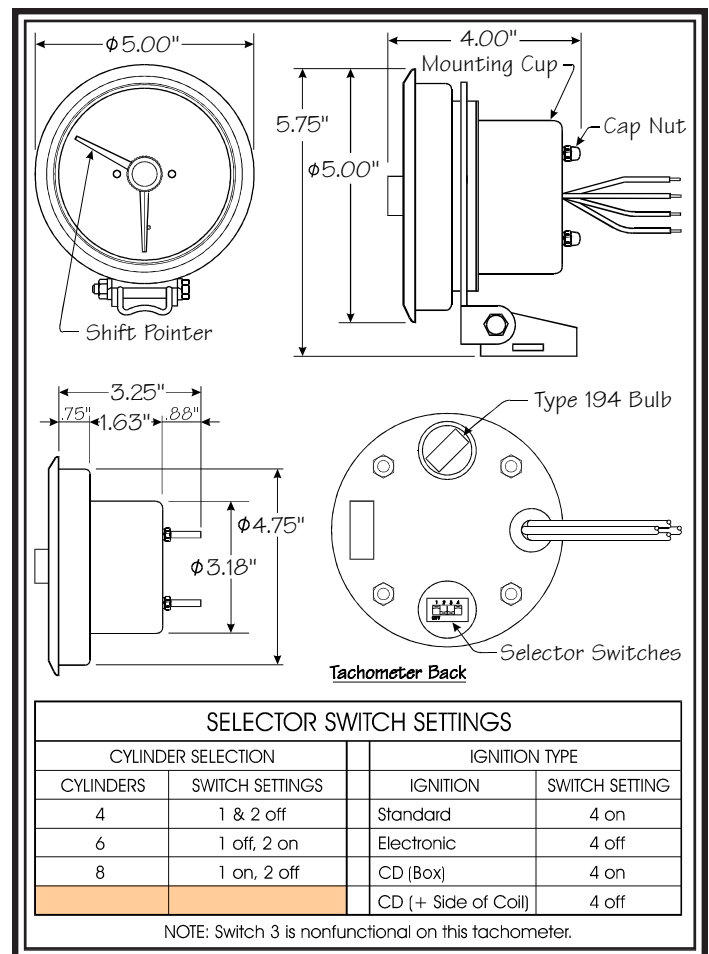

Diagram A

Street Eliminator Dimensions and Switch Settings

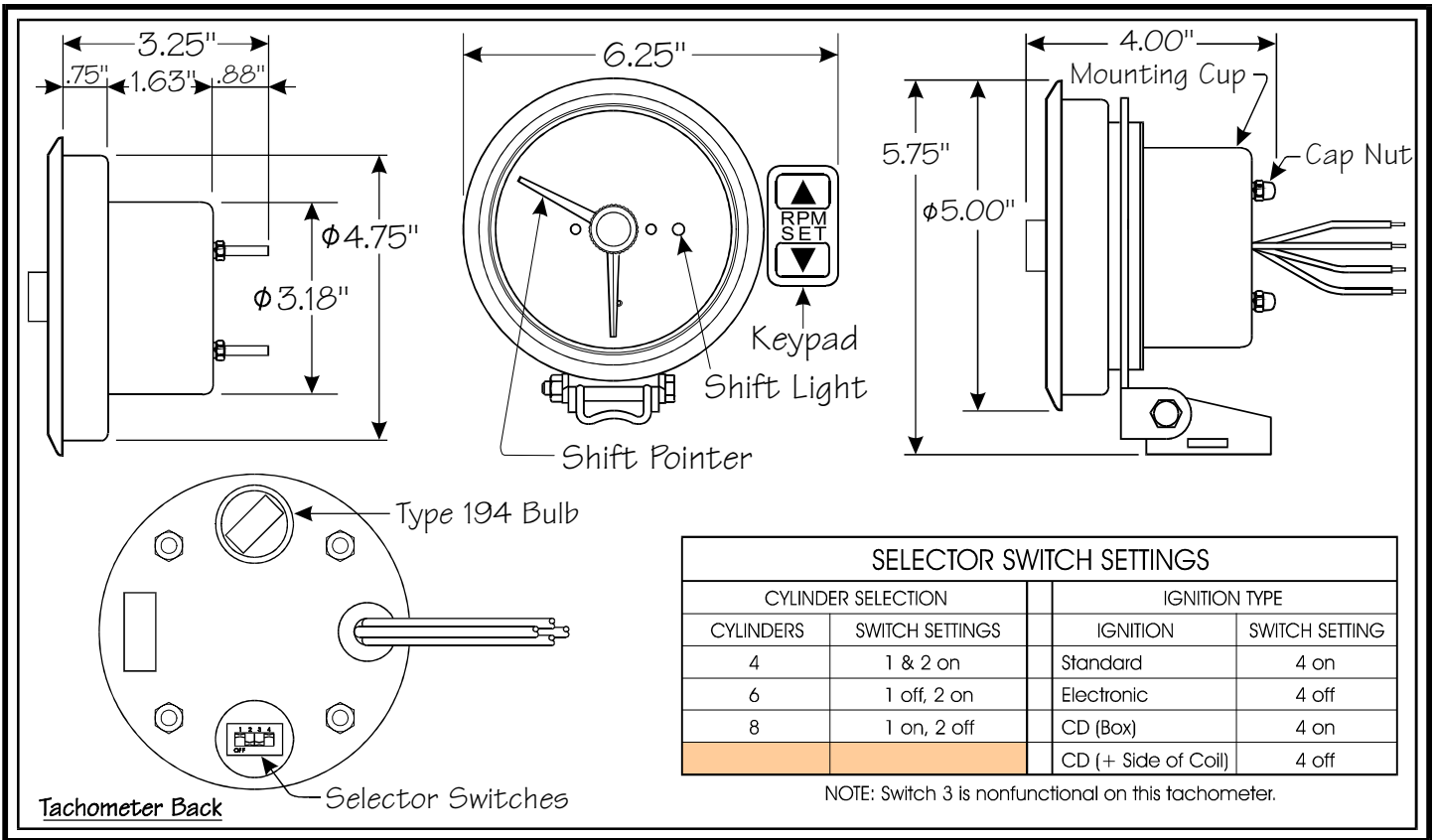

Diagram B
Comp Eliminator Dimensions and Switch Settings

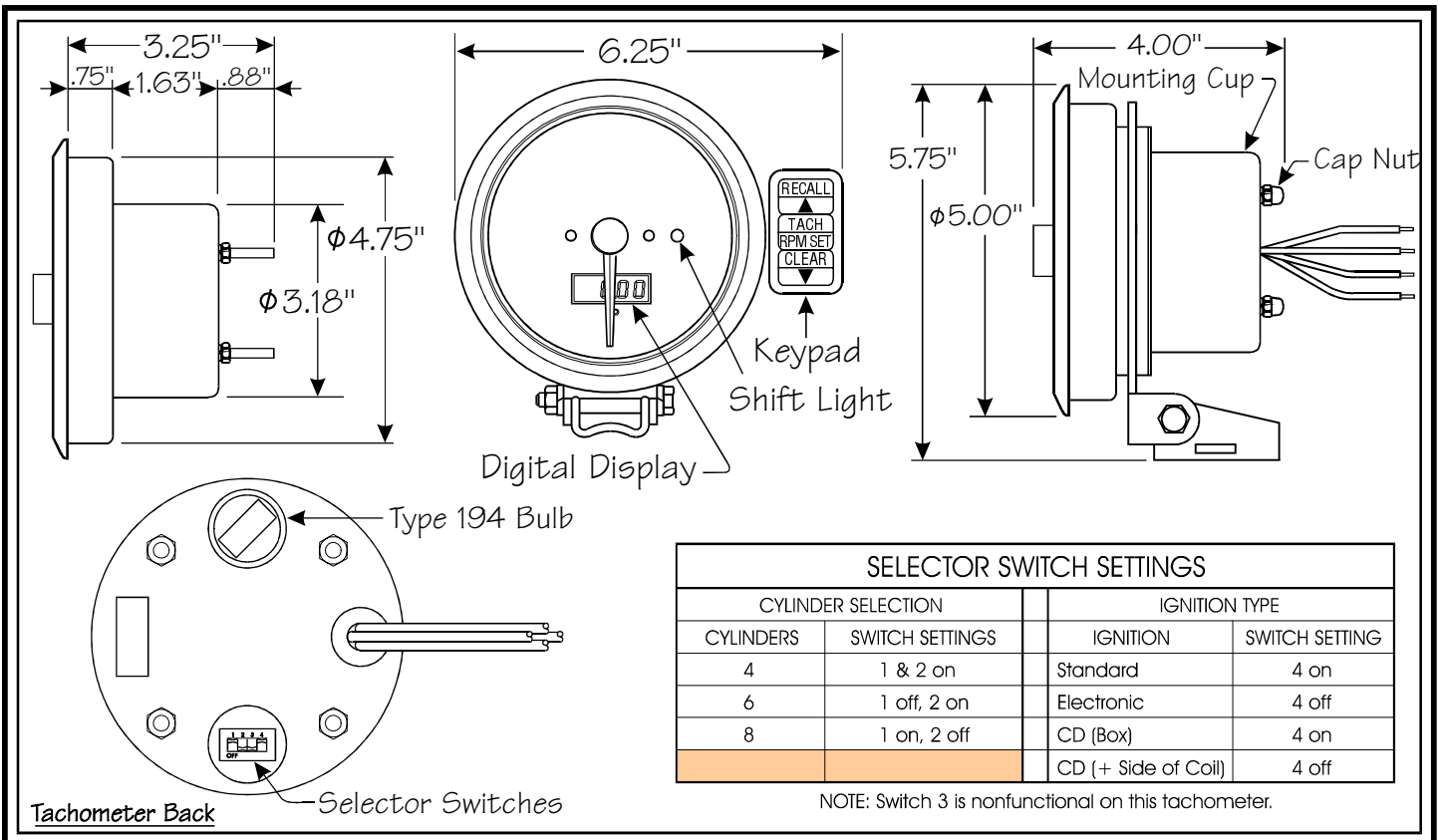

Diagram C
Pro Eliminator Dimensions and Switch Settings

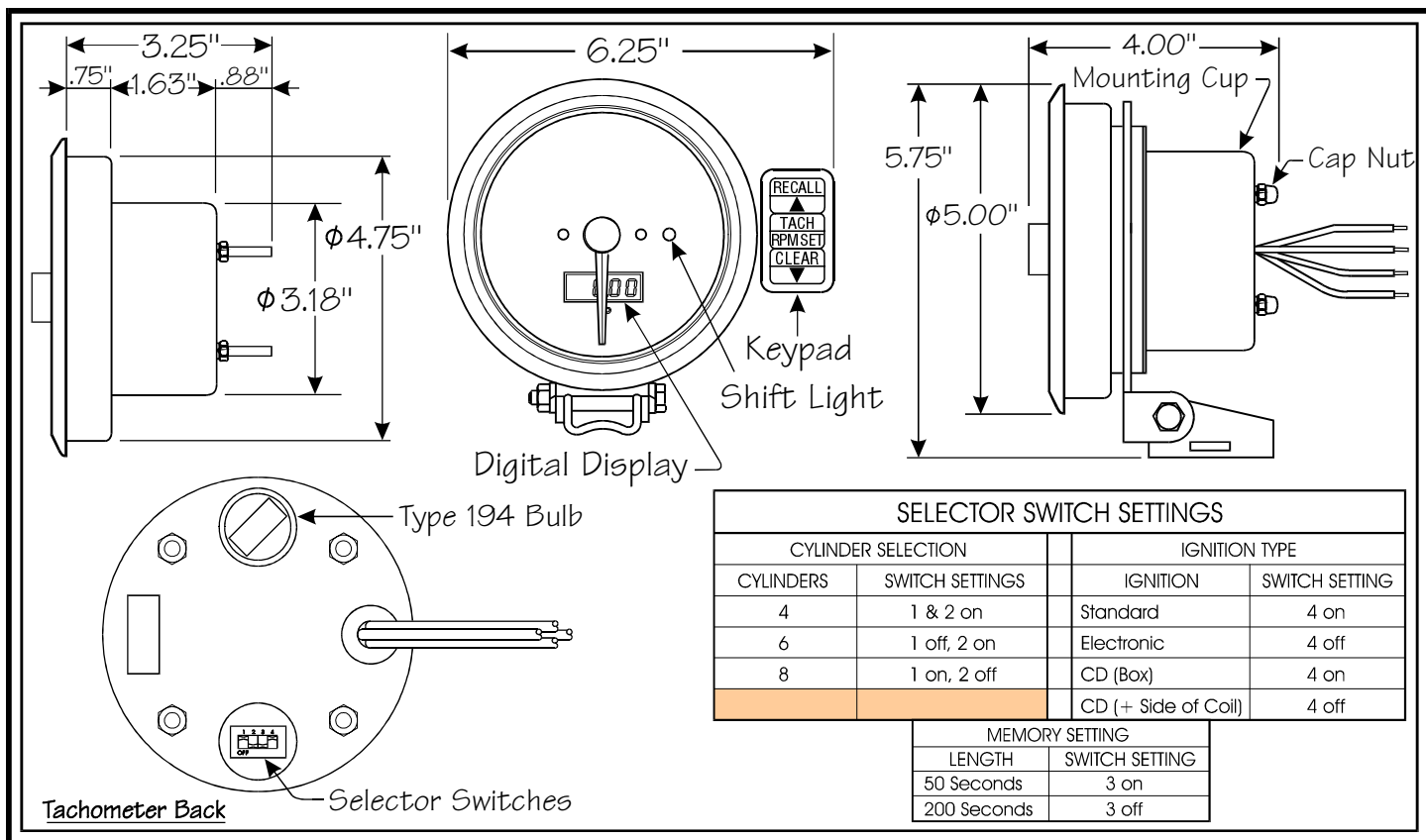

Diagram D

Top Eliminator Dimensions and Switch Settings

4. After you have correctly positioned the selector switches to exactly match your cylinder and ignition type, reassemble the mounting cup to the rear of the tachometer with the four (4) cap nuts.

II. Mounting the Tachometer

1. Select a location to mount the tachometer. **Eliminator** Tachometers can be mounted in four different ways, depending on your preference. They can be: ❶ Column or roll bar mounted. A short contoured foot is included so you can mount the tachometer this way. ❷ In-dash shock mounted. ❸ In-dash flush mounted with an optional U-bracket (#240 104). ❹ Top-dash mounted with an optional long foot (#240 103) for stability.

2. Mount the tachometer, making sure it does not rest against glass, the windshield post, or the roll bar. (NOTE: To ensure proper operation, don't mount the tachometer too close to any electrical items like an ignition system box, coils, or an electrical fuel pump. The wires from these shouldn't be routed by the tachometer, either.) Recommended installation is on the steering column using a band clamp available at any local auto parts store. In some instances the drilling of new holes for the repositioning of the keypad may be necessary. For mounting on the dash, use the optional long mounting bracket #240 103. Use the holes provided in the bracket to secure the tachometer. Flush dash mounting requires a 4¾" hole and the optional U-bracket #240 104.

For competition dash mounting, the rubber mounting grommet supplied can be used. This requires a 3½" hole. Remove the rubber grommet from the mounting ring and place the tachometer into the hole. The mounting cup can be used for a mounting bracket. Mounting without the grommet requires a 3¾" hole. If the dash panel is ½" thick or less, the mounting cup can be used for a bracket. Or, use a modified in-dash bracket #240 104.

3. The keypad can be remote mounted using the optional 6' remote cable #240 207. Remove the keypad from the mounting ring, then remove the mounting cup. Unplug the cable from the back of the tach housing. Insert the male end of the extension cable into the back of the tach. Then insert the male end of the control pad cable into the female end of the extension cable. Reattach the mounting cup, then mount the keypad in the location of your choice.

III. Wiring the Tachometer

1. Remove the key from the ignition and disconnect the negative terminal from the battery post.

2. Wire the tachometer to the vehicle as shown in Diagram H on Page 4. Please understand that proper wiring must be maintained throughout your vehicle. If it isn't, the tachometer may pick up signals that have been produced by electrical devices other than the ignition system. Don't coil up excess tachometer wires during installation. Cut wires and cables to length, and route them making sure they can't be

pinched by pedals or levers. When running cables through areas like firewalls, eliminate wire chafing by using chassis grommets. Proper battery voltage—from 10.5 to 16.5 volts—must be maintained in the vehicle during operation. Don't use solid core ignition wires. Ignition wires must be in good condition. If erratic tachometer readings occur, check all wires for proper resistance values. You'll note that we have included shielded cable and Posi-Lock™ Connectors for your tachometer installation. We highly recommend that you use these to help insure proper operation. Splice the wires from the tachometer to the shielded cable using the Posi-Lock™ Connectors as shown in Diagram E.

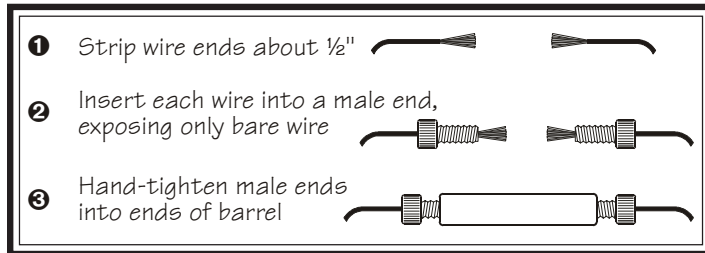

Diagram E

Connect tach wires to insulated cable with **Posi-Locks™**

3. Refer to your engine manual and/or the manufacturer's manual for the location of the tachometer signal connection for a voltage-triggered tachometer. Typical connections are found in the box below. Wire to a magneto ignition using the optional Magneto Interface Box as shown in Diagram F.

IGNITION	TYPE	CONNECTIONS
Standard	points/breakerless	negative terminal on coil
CD	points	points connection to CD box
	breakerless	positive terminal on coil
Electronic	MSD, ACCEL, MALLORY, DDIS (distributorless), etc.	Tach output terminal on ignition box, or points connection to ignition box, or negative coil

For racing applications, connect both the red wire for power and the white wire for illumination to the red wire in the shielded cable used to connect the tach to the ignition.

This will cause the tachometer to stay illuminated continuously during operation, but will help insure the shielding of the tachometer. For non-racing applications, or applications with a low risk of radio-frequency or electromagnetic interference, the white wire from the tachometer can be wired directly to the light switch for illumination only when the lights are turned on. Refer to the wiring in Diagram G.

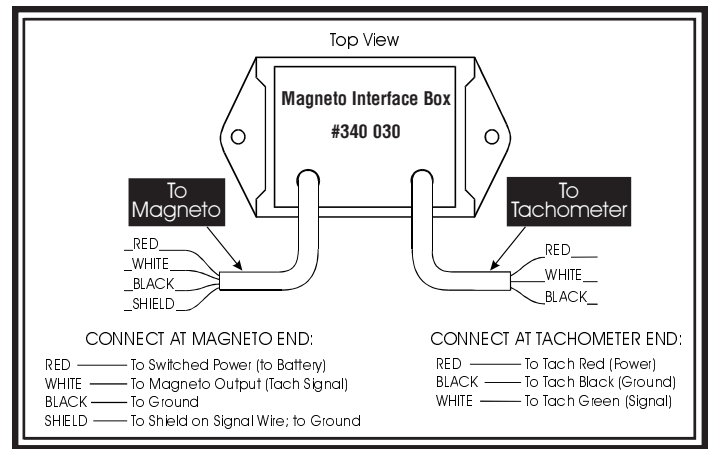

Diagram F

Magneto Interface Box Wiring Instructions

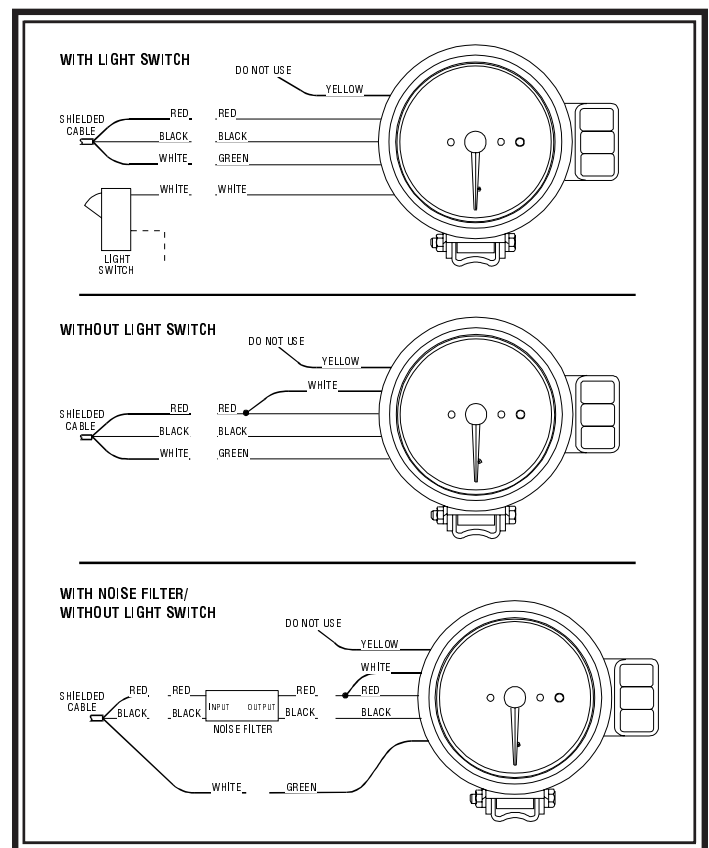

Diagram G

Wiring With and Without a Light Switch

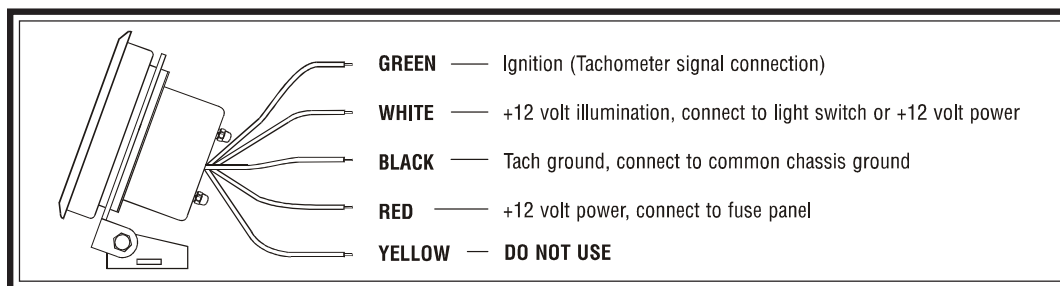

Diagram H

General Wiring Information

CONNECTING TO AN MSD-7AL IGNITION

1. Connect the tach using the 10' shielded cable included with the tachometer. Peel approximately 3 to 4 inches of the outside covering and aluminum shielding from the gray cable. This will reveal four individual wires. Three will be insulated and one will be uninsulated.
2. Strip ½" of the insulation from the black, red and white covered wires.
3. Combine the black and uninsulated wires, which will be used for the ground, into a ⅝" ring terminal.
4. On the end of the white insulated wire, which will be used for the tach signal, install a ¼" female spade terminal.
5. Complete the ignition end of the cable by installing a ¼" flange spade terminal on the red wire that will be used for power.
6. Now connect the cable to the MSD-7AL box as shown below in Diagram I. Connect the "O" ring with the black and uninsulated wire to the terminal labeled "GROUND."
7. Slide the female terminal with the white insulated wire onto the terminal labelled "TACH."
8. Place the "U" connector with the red wire on the

terminal labeled "IGNITION." Make sure all of your connections are tight and clean.

9. Route the shielded cable through the car as desired. Make sure no wires can be pinched by pedals, levers, etc. Then cut the cable to length, leaving a little extra for error.

10. Peel back approximately 1½" of the gray cover, and the shield, from the tachometer end of the shielded cable. Cut the uninsulated wire down to the base of the shielding. Do not—UNDER ANY CIRCUMSTANCES—connect the shield to the tachometer.

11. Strip about ½" of insulation from the ends of the wires. Strip the same amount of insulation from the tachometer wires. **We strongly recommend using the provided Posi-Lock™ connectors for splicing the tachometer wires to the shielded cable.** Install them now. Refer to Diagram E.

12. Connect the black wire from the tachometer to the black wire of the shielded cable (GROUND).

13. Connect the green wire from the tachometer to the white wire in the shielded cable (TACH SIGNAL).

14. Finally, connect the red wire from the tachometer to the red wire in the shielded cable. The remaining white tachometer wire is for illumination, and is connected as

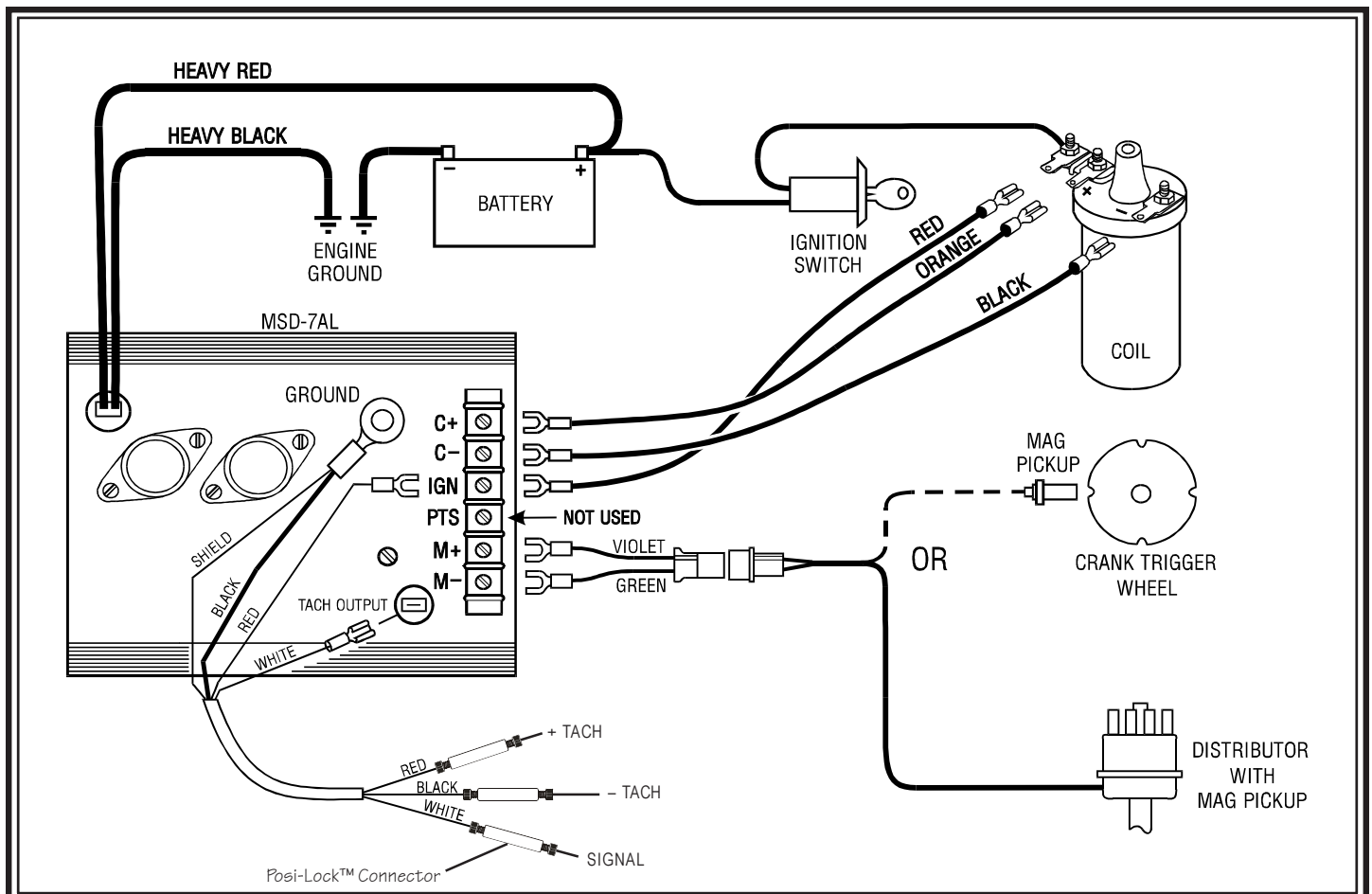

Diagram I
Wiring to MSD-7AL Ignition

YOU MUST USE TWO SETS OF SHIELDED WIRE FOR THIS INSTALLATION!

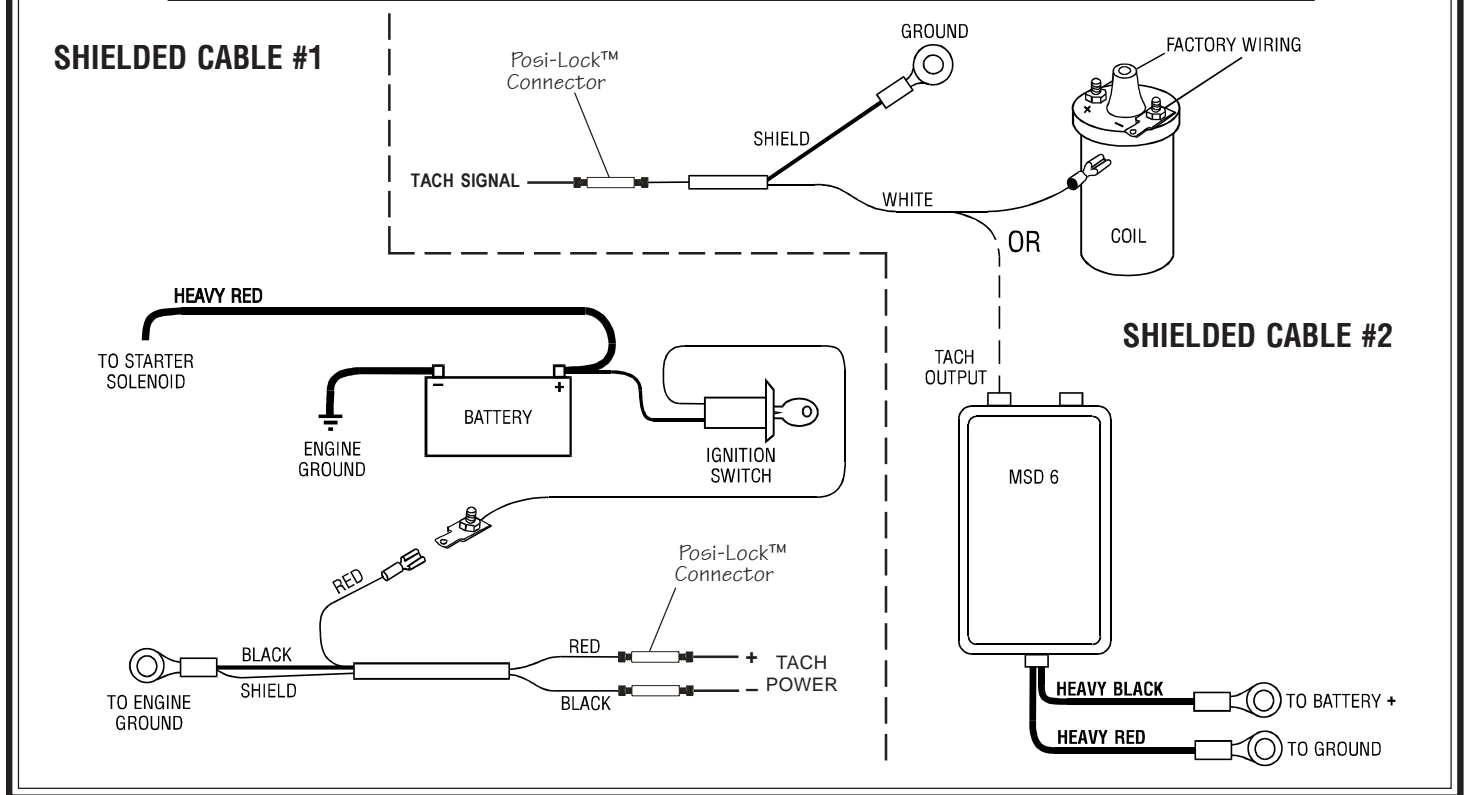

Diagram J

Wiring from the Tachometer to the Ignition Coil or MSD-6

described on Page 4, in the text and in Diagram G.

CONNECTING TO THE IGNITION COIL OR MSD-6

1. When connecting to the negative post of the ignition coil or to the MSD-6 box, run the shielded cable—included with the tachometer—for the TACH SIGNAL, the POWER and the GROUND wires.
2. Ground the shielded wire at the coil. Leave the shield unconnected at the tachometer. Do not, UNDER ANY CIRCUMSTANCES, connect the shielding to the tachometer.
3. Connect the red tachometer “POWER” wire to the ignition power, as seen above in Diagram J. Under normal circumstances, this connection should work properly. However, the power may need to be run through a separate shielded cable directly from the battery, in order to escape as much noise as possible. If this is the case, a 3-Amp, in-line fuse and separate power switch should be used. Again, refer to Diagram J, above.

Tachometer Operation

The Eliminator series consists of four different tachometers—the Street Eliminator, the Comp Eliminator, the Pro Eliminator, and the Top Eliminator. Each is designed to give the ultimate flexibility in operation and function. Operation of these state-of-the-art tachometers is profiled in this section.

I. Street Eliminator Operation

This tachometer is designed for those individuals whose needs include only engine RPM monitoring with a manual shift pointer. This orange pointer, in the center of the tachometer, can be used as a shift point indicator, a reminder not to exceed a certain RPM, or as a stall point indicator.

1. To operate, move the shift pointer by simply turning the easy-to-hold knob in the center of the tachometer face to the RPM you wish to highlight.

II. Comp Eliminator Operation

This tachometer features the same manual shift pointer as the Street Eliminator, as well as a super bright red LED shift light. The Comp Eliminator shift pointer works the same way as the Street Eliminator shift pointer. See the above section for details. To set the LED shift light:

1. Press the RPM set button on the key pad.
2. Press the up arrow until the red pointer indicates the RPM at which you would like the shift light to illuminate.
3. To lower the RPM, press the down arrow.
4. Once you have chosen your desired RPM, push the RPM set button in the center of the keypad again. The microprocessor



will now store the RPM you have selected, and return the tachometer to the functional mode.

III. Pro Eliminator Operation

The **Pro Eliminator** not only gives you the advantages of an LED shift light, but also allows you to set your RPM in precise increments of 10 RPM. And, the **Pro Eliminator** will record and store the highest RPM your engine reaches during the tachometer's memory cycle—that is, since the last time you cleared the memory. Set your shift point as follows:

1. Press the "RPM SET" button on the keypad. This will lift the pointer from the LED display window.

2. Press the up arrow until the LED indicates the desired RPM shift point.



3. Should you need to lower the shift point, simply

press the down arrow.

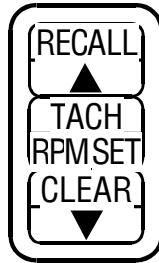

4. To return the tachometer to the operation mode, push the button marked "RPM SET" again. The microprocessor will store the shift point you set.

5. To activate the recall function and reveal the highest RPM level reached during the memory cycle, press the "RECALL" button on the keypad. The digital display will show the peak RPM level achieved since you last pushed the "CLEAR" button. This display will last two seconds. To keep the peak RPM level displayed longer than two seconds, press and hold down the "RECALL" button. The display will disappear when you release the "RECALL" button.

IV. Top Eliminator Operation

VDO Instruments' **Top Eliminator** is the ultimate recording tachometer. In addition to all of the previously mentioned benefits in our other **Eliminator** tachometers, the **Top Eliminator** enables you to record and play back the tachometer readings for an entire 50-second or 200-second time period. The tachometer has four modes of operation:

1. Normal tach mode (TACH); the tachometer is in the normal TACH mode when first turned on. The LED display will show "6.00."
2. Shift light RPM set mode (RPM SET); the RPM SET mode is used for setting the RPM level for the shift light.
3. Recording mode; the tachometer is capable of recording 50 seconds or 200 seconds of the tachometer's activity.
4. Playback mode (RECALL); the tachometer will play back the recording it made of the tachometer run in slow motion—showing elapsed time and RPM values.

Look at the tachometer and you will notice three distinctive features:

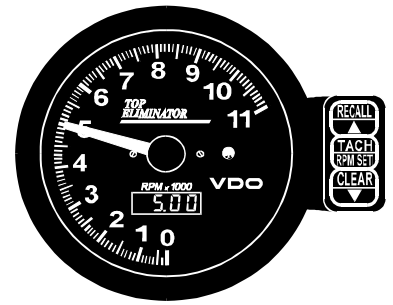

1. A 4-digit LED display at the six o'clock position. This shows the RPM shift point (e.g. 6.00 = 6000 RPM). The display will also indicate when you are recording and will show actual elapsed time in the playback mode.

2. An ultra-bright LED shift light at the 3 o'clock position. This will turn on and stay on as long as your engine exceeds the pre-set RPM shift point.

3. A keypad mounted on the right side of the tach. This keypad is used to shuttle the tachometer between its four modes, to set the RPM value of the shift light, to record tachometer activity, and to activate the playback. To operate the keypad and set the tachometer:

1. Push the TACH/RPM SET button. Pushing this button toggles the tachometer between the normal TACH mode and the RPM SET mode. In the RPM SET mode you can set the RPM at which you want the shift light to illuminate. To set this shift point, make sure the tachometer is in the RPM SET mode. You can tell when tach is in this mode by looking at the digital display. A small dot appears next to the last digit on the right when the tach is in the RPM SET mode.

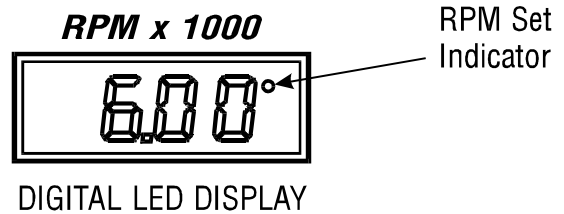

When the tach is in the RPM SET mode, the functions illustrated on the bottom half of each keypad button become active ("▲", "▼", and RPM SET). Also, the RPM indicator needle moves out of the way so you can easily read the LED display.

2. Push the up arrow (▲) until you reach the RPM speed at which you wish the LED shift light to illuminate. If you go too far, push the down arrow (▼) until you get the shift point exactly where you want it (in exact increments or decrements of 10 RPM). Changing the shift point from 6.00 to 8.34, for example, changes the shift point value up from 6000 to 8340 RPM. The shift light will come on at exactly 8340 RPM.

3. Once you have input the desired RPM level, push the RPM SET button once again. The tachometer shuttles back to the TACH operating mode, and the digital display now indicates the new shift point. The dot in the upper right corner of the display will disappear, and the pointer will return to the actual engine RPMs.

4. To record and playback, press the RPM SET button. The tachometer will return to the normal TACH operating mode. The functions designated on the top half of each keypad button will now be active.

5. Press the CLEAR button to erase any previous recordings. When the memory is erased the display will display three dots (. . .) to indicate that the tach is recording. During this cycle, the tach will record for either 50 or 200 seconds, whichever length you selected when you programmed the tachometer. When the tach has finished recording, the display will again display the RPM value you set as your shift point.

6. Press the TACH-RPM SET button during recording if you wish to stop that function and return to the normal TACH operating mode. You can turn off your engine before recording has been completed without losing any information. The tachometer also will remember your latest recording even if you remove the power or battery leads.

7. Press the RECALL button to play back what you have recorded. Playback occurs in slow motion—one-third actual time—so you can really study the information. The LED display will show elapsed time while the pointer is showing the RPM cycle captured during the recording period. As an example, a ten-second run requires thirty seconds to view; but the digital display will show ten seconds as it links the real time of the run to the recording.

8. Press the TACH-RPM SET button during playback if you wish to return to the normal TACH operating mode. The stored information will be saved until the next time you press the CLEAR button.

Troubleshooting

WHEN THE POINTER STAYS AT FULL SCALE —

If the tach is turned off during replay and the pointer was over 4000 RPM, the pointer may swing to full scale. Just turn on power to the tach and the pointer will reset.

THE TACH POINTER JUMPS ERRATICALLY, THE SHIFT LIGHT FLASHES RANDOMLY, OR THE DISPLAY SHOWING THE SHIFT POINT GOES BLANK AND THE POINTER GOES TO 4000-6000 RPM REGARDLESS OF ACTUAL SPEED —

The cause of any combination of these—worsened under racing conditions—is extreme electrical noise attributed to:

A. **LOW BATTERY VOLTAGE.** The operating voltage for the Eliminator Tachometer is 10.5 volts — 16.0 volts.

B. **INADEQUATE WIRING.** All wiring should be kept as direct as possible without having excess wires coiled behind the dash. Avoid bundling power wires with signal wires and having loose-ended power wires. These will act as transmitting antennas for noise generated by the ignition system, fuel pump, etc. The MSD crank trigger or mag pickup ignition trigger should not be routed near spark plug wires or high current wires.

C. **IGNITION WIRES.** Solid core metallic wires, old wires with cracked insulation, or wires with improperly crimped ends or breaks in the conductors emit large amounts of electromagnetic interference (EMI). Ignition wires can be checked for defects with a standard ohmmeter. Heli-core wires (MSD) will read 150 ohms per foot. ACCEL spiral core wire will read 500–750 ohms per foot. Standard resistor wires will read 5000–10,000 ohms per foot.

Correct these problems first. If tach problems persist—

A. **WHEN CONNECTING TO MSD-7AL:** Connect the tach using the shielded cable provided. Connect the shield and ground wire to the ground post on the MSD box or the main MSD ground. Connect the power wire to the ignition terminal on the MSD box, and the signal wire to the tach output terminal on the MSD box. At the tach end, connect the red wire to power, the green wire to signal, and the black wire to ground (see Diagram I on Page 5). **DO NOT** connect the shield to the tach under any circumstances.

B. **WHEN CONNECTING TO THE IGNITION COIL OR MSD-6:** When connecting to the negative post of the ignition coil or to the MSD-6, run a separate shielded wire for the signal and the power/ground wires. The shielded wire from the coil should be grounded at the coil and the shielding left unconnected at the tach end. The power may need to be run through a shielded wire directly from the battery to escape as much noise as possible. If you wire in this way, insert a 3-Amp in-line fuse and a separate power switch (See Diagram J on Page 6).

C. If the shielded wire provided doesn't eliminate all noise interference, a noise filter should be installed on the power/ground wires, as close as possible to the tach. Noise filters—Radio Shack #270-051 or MSD #8830—will eliminate any remaining noise on the power wire from the ignition system, fuel pump, alternator (if equipped), relays, etc. The tach's white illumination wire may also need to be connected with the red power wire after the noise filter. See Diagram G on Page 4. These solutions should solve any problem you encounter. But if you still need assistance, call our Technical Service Coordinator at 1-800-986-5836.

VDO Limited Warranty

VDO North America warrants all merchandise against defects in factory workmanship and materials for a period of 24 months after purchase. This warranty applies to the first retail purchaser and covers only those products exposed to normal use or service. Provisions of this warranty shall not apply to a VDO product used for a purpose for which it is not designed, or which has been altered in any way that would be detrimental to the performance or life of the product, or misapplication, misuse, negligence or accident. On any part or product found to be defective after examination by VDO North America, VDO North America will only repair or replace

the merchandise through the original selling dealer or on a direct basis. VDO North America assumes no responsibility for diagnosis, removal and/or installation labor, loss of vehicle use, loss of time, inconvenience or any other consequential expenses. The warranties herein are in lieu of any other expressed or implied warranties, including any implied warranty of merchantability or fitness, and any other obligation on the part of VDO North America, or selling dealer.

(NOTE: This is a "Limited Warranty" as defined by the Magnuson-Moss Warranty Act of 1975.)

VDO North America • 188 Brooke Rd. • P.O. Box 2897 • Winchester, VA 22603 • Phone: 540-665-2428